

## OLS 08 V 2000-TSSL

### Laser Through Beam Sensor, Transmitter

- Small design
- Collimated red light laser
- Visible laser spot
- Robust metal casing
- High protection class

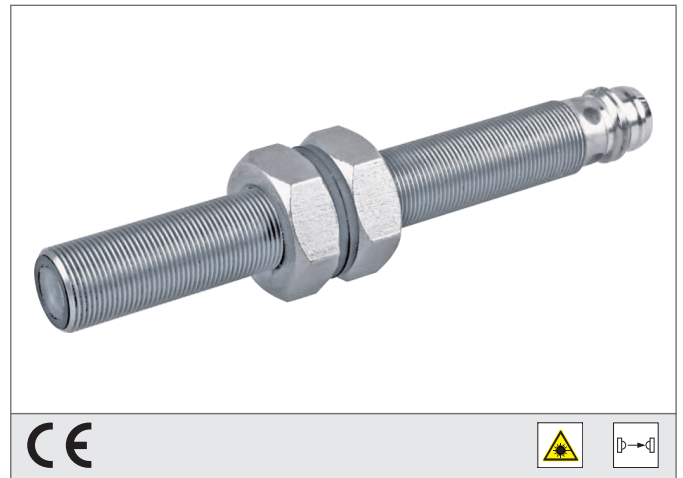

CE

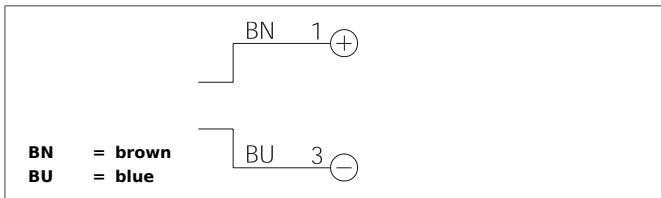

#### Safety instructions

Inproper use may result in hazardous radiation exposure. Pay attention to accident prevention rules and laser class. The instruments are not to be used for safety applications, in particular applications in which safety of persons depends on proper operation of the instruments. These instruments shall exclusively be used by qualified personnel.

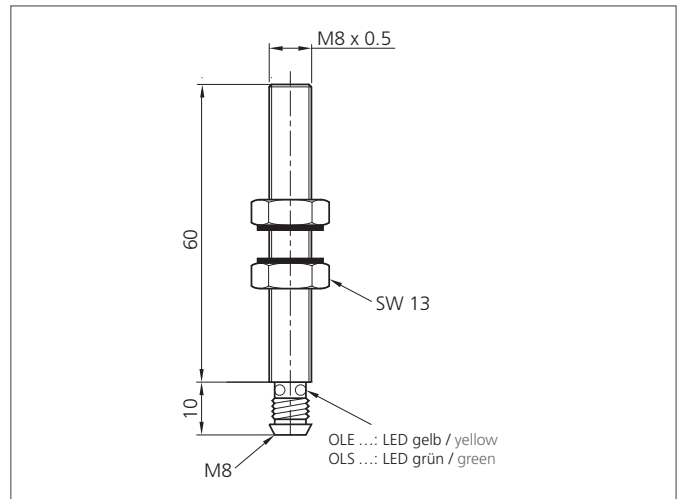

TECHNICAL INFORMATION (typ.)		+20°C, 24V DC
Operating principle		Through beam sensors, transmitter
Evaluation		digital
Size		M8 x 0,5 (thread)
Design		screw
Emitted light		Red light laser, 670 nm, clocked
Laser class		1 (IEC 60825-1)
Service voltage		10 ... 35 V DC
Internal power consumption		< 30 mA
Operating distance		0 ... 2.000 mm
Sensitivity adjustment		no setting elements
Switching frequency		2.000 Hz
Ambient temperature		0 ... +50 °C
Insulation voltage endurance		500 V
Protection class		IP 67
Protection degree		III, operation on protective low voltage
Casing material		stainless steel
Connection		Connector, M8
Connecting cable		TK ...